

The CNC Pitch & Roll Arm Set-204612

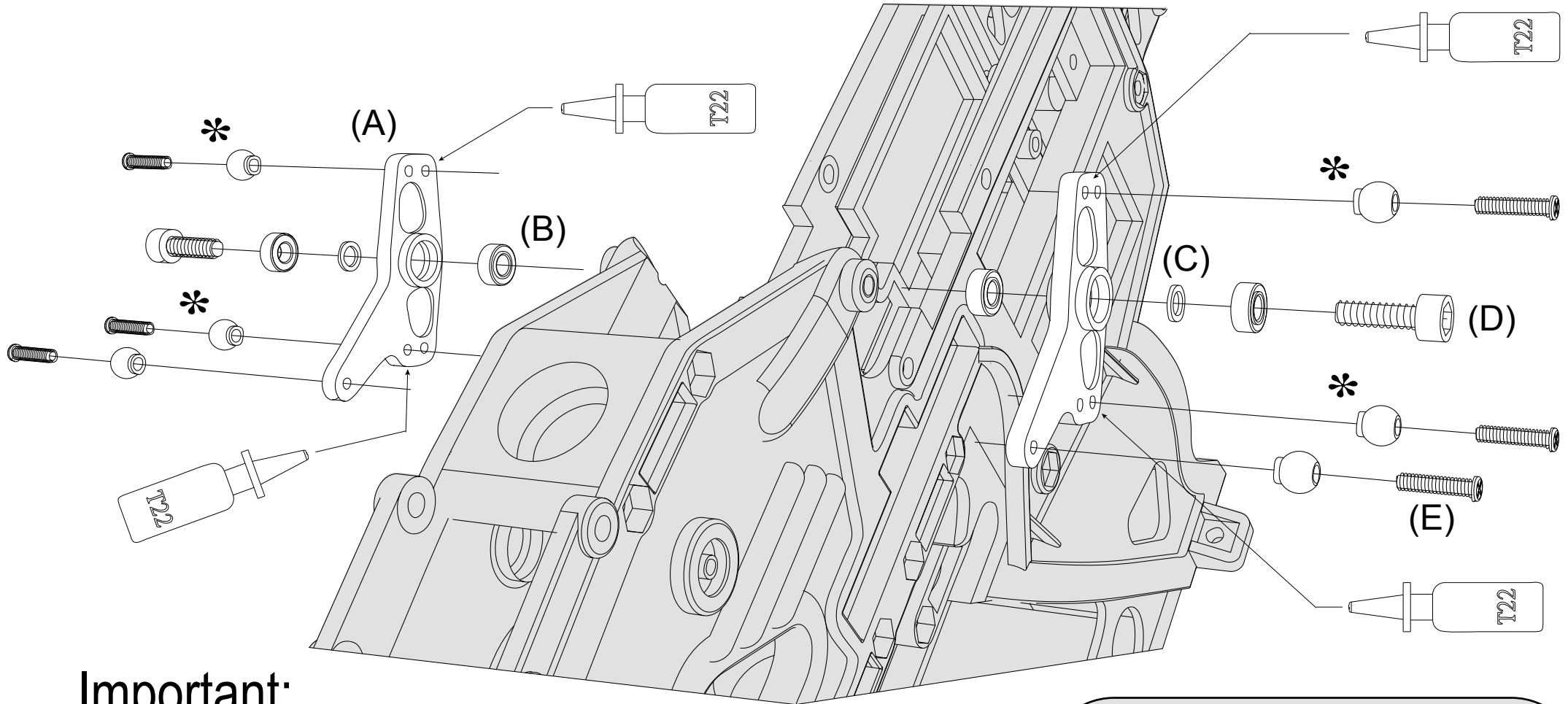

Important:

- 1.The ball position on both arms are different as shown.
- 2.Use Holdtite to adhere every screws to the position as shown.

Instruction:

- A.CNC pitch and roll arm set
- B.Bearing(3x6x2.5) * 4 pcs
- C.Brass washer(3x4.5x0.5) *2 pcs
- D.M3x10 socket screw * 2 pcs
- E.M2x8 screw * 6 pcs