

(GUEC GU-210) Heading Hold Gyro Instruction Manual

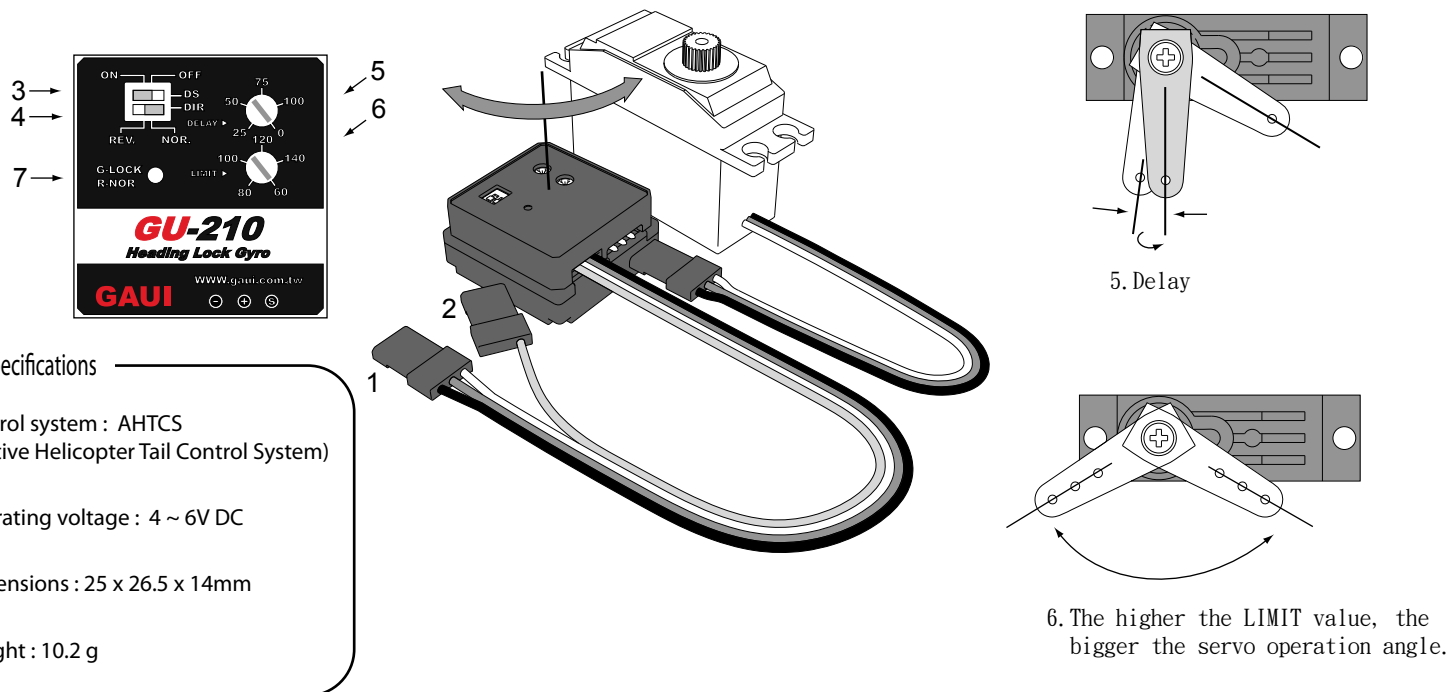

1. Install the GU210 using the double-sided sponge tape which is included in the pack. Make sure that the bottom of the gyro is perpendicular to the direction of the main rotor shaft axis. (as shown in figure above)
2. Connect the plug (1) to receiver rudder channel (CH4). And connect the plug (2) to receiver channel 5. Please refer to the instruction manual of your transmitter for the connecting of the plug (2), it varies according to the different types of transmitters.
3. Connect the rudder servo to Gyro (Make sure the polarity should be connected correctly). When using a digital servo as the rudder servo, set the DS switch (3) to the ON position.
4. Set the transmitter revolution mixing (pitch->rudder) to 0% or OFF and turn on the transmitter power, then turn on the receiver power (shared to Gyro). Since the GU210 initializes the data when the power is turned on, set the rudder stick to the neutral position and do not move the helicopter for approximately 3 seconds. When the monitor LED (7) lights in green , the gyro is operating in the Heading Hold gyro mode. If the power is turned on in the normal gyro mode, the monitor LED (7) will light in red. Next, set the transmitter gyro sensitivity switch to the normal gyro mode position and check the linkage, In the rudder neutral position, connect the linkage so that the servo horn and control wire are perpendicular. Do not use the transmitter trim to adjust the neutral position of the tail pitch slider, large rudder neutral position deviation may require readjustment of the linkage or the rudder servo mounting position.
5. when the nose of the helicopter moves to the right, the gyro should move the rudder servo to the direction as moving the rudder control stick to the left , if not, the gyro direction is incorrect. Set the switch (4) to the REV. position.
6. Set the delay trimmer (5) to "0" value if using the digital servo or the high speed analogue servo. It is recommended that set the the delay trimmer (6) to "50" value to endure the analogue servo life cycle longer. (as shown in fig.5)
7. Move the rudder stick to the left and right and adjust the limit trimmer (6) so that the tail pitch slider does not strike the tail mechanism. During flight, the servo will not operate beyond this limit(as shown in fig.6).
After the GU210 gyro installed, the Rudder servo is controled by the gyro which sends control signals to it, and the Travel Volume (ATV / End Point) function on transmitter was changed into control the speed of tail spin (Yawing). You may adjust the speed of tail spin by this function but make sure that use the limit trimmer (6) on gyro to adjust the limit of the tail pitch slider.
8. Start sensitivity adjustment with a gyro sensitivity of 70 ~ 80% when hovering and 60 ~ 70% during flight and search for the best sensitivity for the helicopter used.
9. In the Heading Hold gyro mode, if the tail swift to one side slowly while in hovering, use the transmitter rudder trim to adjust the tail to the suitable position.